

## VARIO ELECTRIC HEIGHT ADJUSTABLE ASSEMBLY INSTRUCTIONS WALL MOUNTED FRAME

**PRIOR TO ASSEMBLY ENSURE ALL GEARS ARE GENTLY WOUND DOWN TO THEIR FULLY CLOSED POSITION**

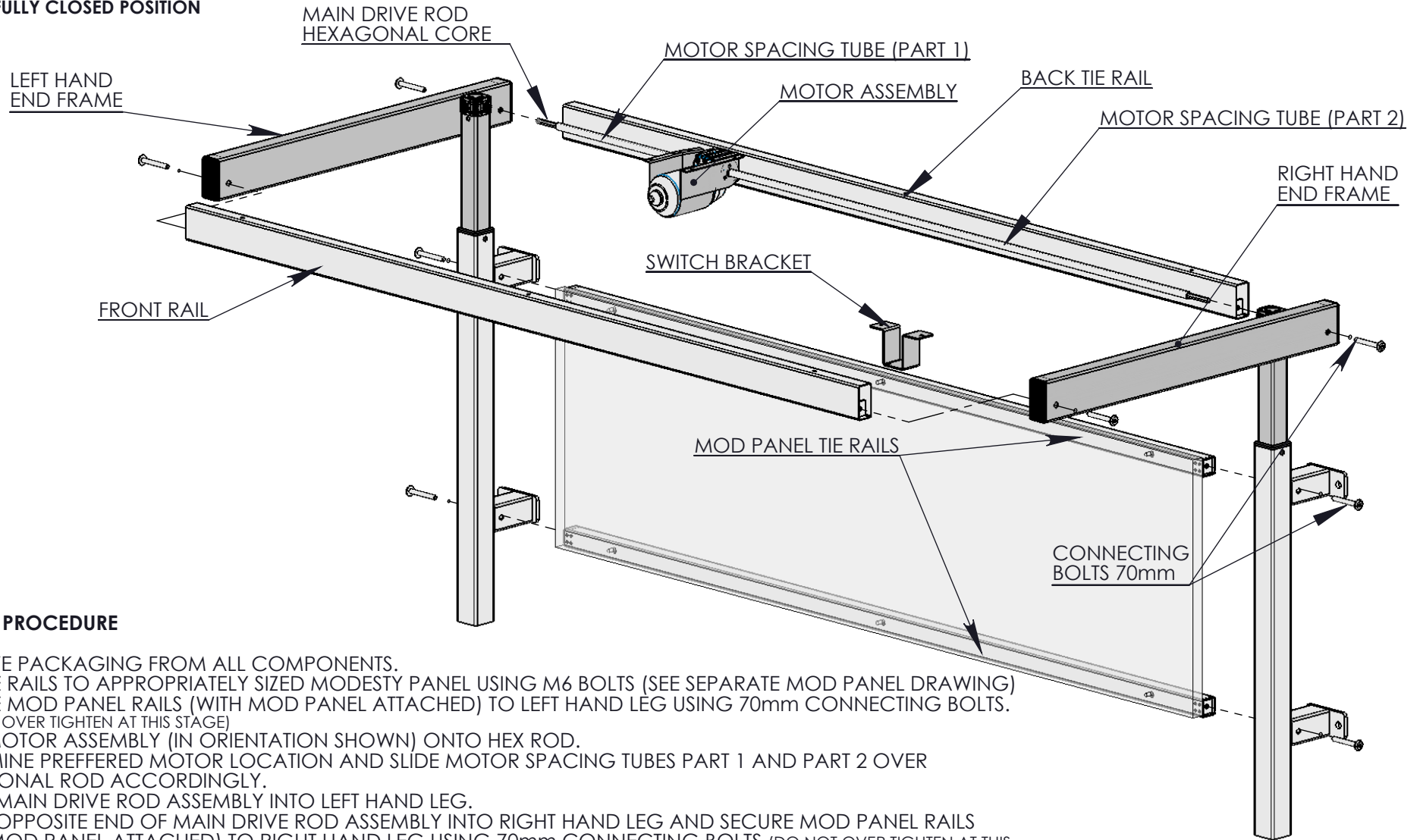

### ASSEMBLY PROCEDURE

- REMOVE PACKAGING FROM ALL COMPONENTS.
- SECURE RAILS TO APPROPRIATELY SIZED MODESTY PANEL USING M6 BOLTS (SEE SEPARATE MOD PANEL DRAWING)
- SECURE MOD PANEL RAILS (WITH MOD PANEL ATTACHED) TO LEFT HAND LEG USING 70mm CONNECTING BOLTS. (DO NOT OVER TIGHTEN AT THIS STAGE)
- SLIDE MOTOR ASSEMBLY (IN ORIENTATION SHOWN) ONTO HEX ROD.
- DETERMINE PREFERRED MOTOR LOCATION AND SLIDE MOTOR SPACING TUBES PART 1 AND PART 2 OVER HEXAGONAL ROD ACCORDINGLY.
- INSERT MAIN DRIVE ROD ASSEMBLY INTO LEFT HAND LEG.
- INSERT OPPOSITE END OF MAIN DRIVE ROD ASSEMBLY INTO RIGHT HAND LEG AND SECURE MOD PANEL RAILS (WITH MOD PANEL ATTACHED) TO RIGHT HAND LEG USING 70mm CONNECTING BOLTS (DO NOT OVER TIGHTEN AT THIS STAGE)
- SECURE FRONT AND BACK RAILS WITH 70mm CONNECTING BOLTS. (DO NOT OVER TIGHTEN AT THIS STAGE)
- WITH THE TOP LYING ON THE FLOOR TURN FRAME UPSIDE DOWN AND SECURE FRAME TO TOP USING SUITABLE SCREWS.
- SECURE MOTOR ASSEMBLY TO UNDERSIDE OF TABLE USING SUITABLE FIXINGS.
- POSITION SWITCH BRACKET IN PREFERRED LOCATION AND SECURE USING SUITABLE FIXINGS.
- POSITION CONTROL BOX IN PREFERRED LOCATION AND SECURE USING SUITABLE FIXINGS
- CONNECT ALL CABLES AND LEADS. SECURE TO TOP USING SELF ADHESIVE TIE HOOKS AND ZIP TIES.
- TIGHTEN ALL CONNECTING BOLTS.
- POSITION FRAME WORK AGAINST WALL AND SECURE USING SUITABLE FIXINGS.
- ENSURE WALL IS TRUE, "IRREGULARITIES" WILL RESULT IN FRAME BEING PULLED OUT OF SQUARE CAUSING SQUEAKING DURING OPERATION.

Rack Systems (Engineering) Ltd  
19-25 Dove way,  
Kirkby Mills Industrial Estate,  
Kirkbymoorside,  
York  
YO62 6QR

Tel; 01751 432647 Fax; 01751 433375