

VARIO HEIGHT ADJUSTABLE ASSEMBLY INSTRUCTIONS WALL MOUNTED FRAME WITH FOOT

**PRIOR TO ASSEMBLY ENSURE ALL
GEARS ARE GENTLY WOUND DOWN
TO THEIR FULLY CLOSED POSITION**

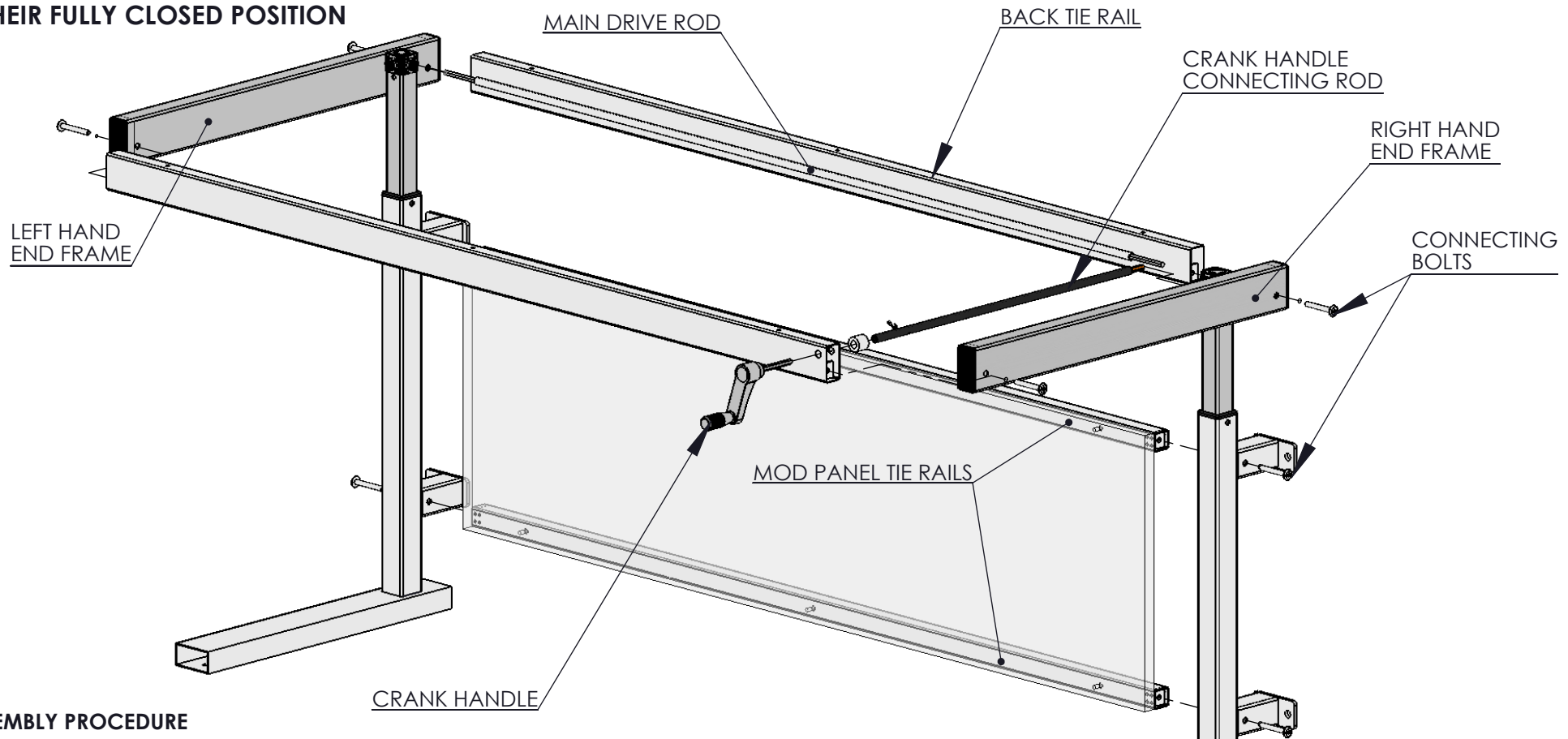

ASSEMBLY PROCEDURE

- REMOVE PACKAGING FROM ALL COMPONENTS.
- SECURE RAILS TO APPROPRIATELY SIZED MODESTY PANEL USING M6 BOLTS (SEE SEPARATE MOD PANEL DRAWING)
- SECURE MOD PANEL RAILS (WITH MOD PANEL ATTACHED) TO LEFT HAND LEG USING 70mm CONNECTING BOLTS. (DO NOT OVER TIGHTEN AT THIS STAGE)
- INSERT HEX ROD INTO LEFT HAND LEG.
- INSERT OPPOSITE END OF HEX ROD INTO RIGHT HAND LEG AND SECURE MOD PANEL RAILS (WITH MOD PANEL ATTACHED) TO RIGHT HAND LEG USING 70mm CONNECTING BOLTS. (DO NOT OVER TIGHTEN AT STAGE)
- SECURE FRONT AND BACK RAILS WITH 70mm CONNECTING BOLTS. (DO NOT OVER TIGHTEN AT THIS STAGE)
- WITH THE TOP LYING ON THE FLOOR TURN FRAME UPSIDE DOWN AND SECURE FRAME TO TOP USING SUITABLE SCREWS.
- SECURE DRIVE ROD COVER USING SUITABLE FIXINGS.
- SECURE FRAME TO WALL USING SUITABLE FIXINGS.
- TIGHTEN ALL FIXINGS.
- ENSURE WALL IS TRUE "IRREGULARITIES" WILL RESULT IN FRAME BEING PULLED OUT OF SQUARE CAUSING SQUEAKING DURING OPERATION.

Rack Systems (Engineering) Ltd
19-25 Dove way,
Kirkby Mills Industrial Estate,
Kirkbymoorside,
York
YO62 6QR

Tel; 01751 432647 Fax; 01751 433375